Kingdom of Saudi Arabia
Ministry of Health



National eHealth Strategy and Change Management Office
(SCMO)

Enabling Standards-Based eHealth Interoperability

IS0009

Saudi eHealth Core Interoperability Specification for eDispensation

Version 1.0

February 22, 2015

Document Control Number: IS0009 Saudi eHealth Core Interoperability Specification for
eDispensation

THIS PAGE INTENTIONALLY LEFT BLANK

TABLE OF CONTENTS

PREFACE	1
DOCUMENT PURPOSE	1
HOW TO READ THIS DOCUMENT	1
REFERENCES	1
DESCRIPTION	3
DOCUMENT CONVENTIONS	3
Requirements Numbering Conventions:.....	3
Requirements Language	3
METHODOLOGY	4
1. USE CASE OVERVIEW	5
1.1 SCOPE	5
1.2 USE CASE ACTORS AND SERVICES	6
1.3 DESIGN CONSTRAINTS AND ASSUMPTIONS	6
2. CORE INTEROPERABILITY SPECIFICATION REQUIREMENTS	8
2.1 ACTOR MAPPING TO SAUDI EHEALTH INTEROPERABILITY SPECIFICATIONS	8
2.2 INTEROPERABILITY SEQUENCE DIAGRAMS	11
2.2.1 Sequence Diagram Pre-conditions	11
2.2.2 Other Sequence Diagram Requirements	13
2.2.3 Main Flow Sequence Diagram – Paper Prescription or Over The Counter (OTC) Medication.....	16
2.2.4 Main Flow Sequence Diagram – ePrescription Available.....	18
2.2.5 Alternate Flow Sequence Diagram – Manage Dispensation Record	19
2.2.6 Exception Flow Sequence Diagram – Medication Interaction Checking Determines Errors or Warnings.....	20
2.2.7 Exception Flow – Revoke Dispensation Record.....	22
3. EDISPENSATION ACTOR CONFORMANCE	24
3.1 DISPENSER CONFORMANCE	24
3.2 HIE DOCUMENT REPOSITORY CONFORMANCE	26
4. SAUDI EHEALTH CONSTRAINTS ON EDISPENSATION	28
4.1 REQUIREMENTS FOR DISPENSER USE CASE ACTOR	28
4.1.1 Medication Dispenser Technical Actor	28
4.1.2 Pharmaceutical Adviser Technical Actor	29
4.1.3 Medication Dispenser or Prescription Placer Technical Actor Using the Query/Retrieve Medication Records Service.....	29
4.1.4 Medication Interaction Reporting	30
4.2 REQUIREMENTS FOR HIE DOCUMENT REPOSITORY USE CASE ACTOR	31
4.2.1 Community Pharmacy Manager Technical Actor	31
4.2.2 Medication Interaction Checking.....	31
5. REFERENCED DOCUMENTS AND STANDARDS	34

5.1	COPYRIGHT PERMISSIONS.....	36
6.	APPENDIX A – SAMPLE MESSAGES.....	38

LIST OF TABLES

TABLE 1.2-1 USE CASE ACTORS.....	6
TABLE 1.2-2 USE CASE SERVICES	6
TABLE 2.1-1 INTEROPERABILITY CONFORMANCE REQUIREMENTS FOR DISPENSER	8
TABLE 2.1-2 INTEROPERABILITY CONFORMANCE REQUIREMENTS FOR HIE DOCUMENT REPOSITORY	10
TABLE 4.2.2-1 ERROR SEVERITY	32
TABLE 4.2.2-2 SOURCE TYPE	32
TABLE 4.2.2-3 IMPACT OF MEDICATION INTERACTIONS ON THE PROVIDE AND REGISTER TRANSACTION	33
TABLE 5-1 INTERNAL REFERENCES.....	34
TABLE 5-2 EXTERNAL REFERENCES.....	35

LIST OF FIGURES

FIGURE 1-1 E DISPENSATION DOCUMENT ORGANIZATION.....	2
FIGURE 2.2.1-1 PRE-CONDITION SEQUENCE DIAGRAM.....	13
FIGURE 2.2.2.1-1 TRANSACTIONS ASSOCIATED WITH PUBLISH MEDICATION DOCUMENT	14
FIGURE 2.2.2.2-1 TRANSACTIONS ASSOCIATED WITH QUERY/RETRIEVE MEDICATION DOCUMENTS	15
FIGURE 2.2.3-1 TRANSACTIONS ASSOCIATED WITH DISPENSE MEDICATION – PAPER PRESCRIPTION OR OTC	18
FIGURE 2.2.4-1 TRANSACTIONS ASSOCIATED WITH DISPENSE MEDICATION – EPRESCRIPTION AVAILABLE	19
FIGURE 2.2.5-1 TRANSACTIONS ASSOCIATED WITH MANAGING THE DISPENSATION RECORD	20
FIGURE 2.2.6-1 TRANSACTIONS ASSOCIATED WITH DISPENSE MEDICATION – MEDICATION INTERACTION CHECKING WITH ERRORS OR WARNINGS	22
FIGURE 2.2.7-1 TRANSACTIONS ASSOCIATED WITH REVOKING A DISPENSATION RECORD	23

CONFIDENTIALITY STATEMENT:

The Ministry of Health (MOH) of the Kingdom of Saudi Arabia grants to any user of this document, perpetual, royalty-free, nontransferable, nonexclusive, license under its copyrights to access and read the Saudi eHealth Specification. You may not reproduce or use this document or any portion of it, without prior written consent from the MOH. The licenses covered are only to those parts owned or controlled by the MOH itself. If parts of the Saudi eHealth Specification include materials owned or controlled by other parties, licenses to use those products would have to be obtained from that other party.

The MOH offers the licensed material as-is and as-available, and makes no representations or warranties of any kind concerning the licensed material, whether express, implied, statutory, or other. This includes, without limitation, warranties of title, merchantability, fitness for a particular purpose, non-infringement, absence of latent or other defects, accuracy, or the presence or absence of errors, whether or not known or discoverable. To the extent possible, in no event will the authors and licensor be liable on any legal theory (including, without limitation, negligence) or otherwise for any direct, special, indirect, incidental, consequential, punitive, exemplary, or other losses, costs, expenses, or damages arising out of this public license or use of the licensed material, even if the licensor has been advised of the possibility of such losses, costs, expenses, or damages.

Document Revision History

VERSION	DATE	TYPE OF UPDATE	PREPARED/REVISED BY
1.0	February 22, 2015	First Release	eHealth Strategy Management Office – eHealth Standards Department

PREFACE

DOCUMENT PURPOSE

The purpose of this document is to address the Saudi eHealth Core Interoperability Specification for the Dispensation Use Case which is specified in the UC0008 *Saudi eHealth Medication Interoperability Use Case* document. It forms a set of requirements that complements the set of Integrating the Healthcare Enterprise (IHE) Profiles, Health Level 7 (HL7) and Vocabulary Standards required by this specification with Saudi eHealth specific constraints. It also aligns with the Saudi e-Government Interoperability Standards (YEFI) to expedite national adoption.

This eDispensation Core Interoperability Specification is applicable to existing and new information systems that will exchange Health Information. In particular, this Interoperability Specification applies to the deployment of Health Information Exchange (HIE) Platforms such as the Saudi eHealth Exchange (SeHE).

HOW TO READ THIS DOCUMENT

This document contains four normative sections, as well as informative appendices for convenience. The document is structured as follows:

Section 1: Describes the Use Case, including design constraints and assumptions. Please refer to the UC0008 *Saudi eHealth Medication Interoperability Use Case* for workflows.

Section 2 Establishes the core interoperability requirements for the Interoperability Specification.

Section 3: Describes the conformance requirements for the eDispensation Actors.

Section 4: Establishes the Saudi eHealth Constraints on eDispensation.

Section 5: Lists the Saudi eHealth reference documents, as well as the international standards which underpin the Interoperability Specification.

Appendix A: illustrates sample document and messages associated with eDispensations.

REFERENCES

The Saudi eHealth Interoperability Core Specification (IS) is the sole entry point for the technology developers, assessor/testers and certifiers, and the purchasers of IT systems in terms of technical requirements.

It references a number of Supporting Interoperability Specifications:

- IS0001 *Saudi eHealth Core Interoperability Specification for KSA-Wide Patient Demographic Query*
- IS0007 *Saudi eHealth Core Interoperability Specification for Clinical Notes and Summaries*
- IS0008 *Saudi eHealth Core Interoperability Specification for ePrescriptions*
- IS0106 *Saudi eHealth Clinical Documents Constrains Interoperability Specifications*
- IS0101 *Saudi eHealth Security and Privacy Interoperability Specification*
- IS0102 *Saudi eHealth Document Sharing Interoperability Specification*

- IS0200 Saudi eHealth Terminology Repository

The Saudi eHealth Interoperability Specifications include precise references to internationally adopted profiles and standards as well as Saudi specific constraints. Further descriptions and references for the documents identified below are provided in Section 5 Referenced Documents and Standards.

This document fits into an overall specification framework described in Figure 0-1 eDispensation Document Organization.

Implementations are required to conform to the requirements within this Interoperability Specification; all Saudi eHealth referenced Interoperability Specifications and the standards and profiles they specify.

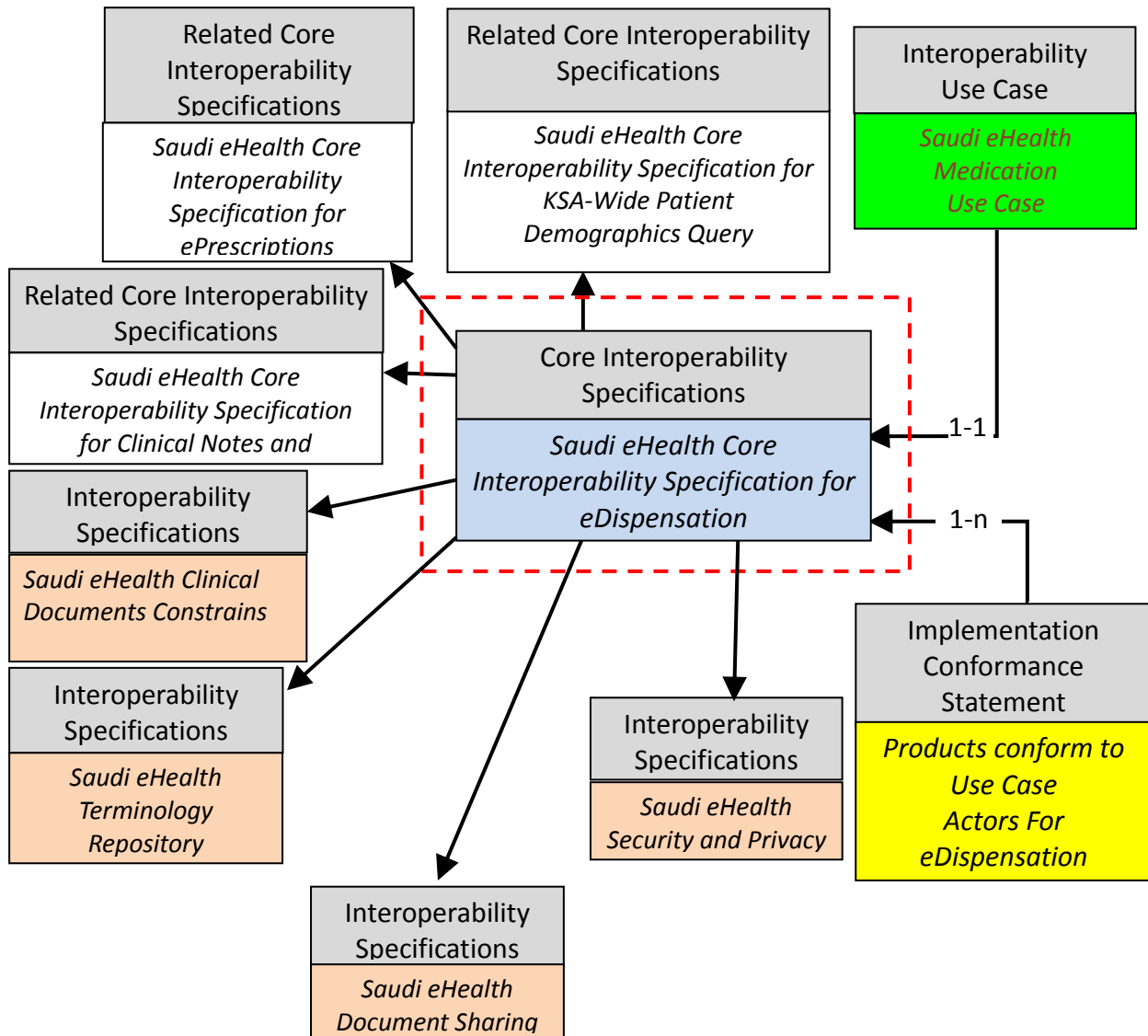

FIGURE 0-1 eDISPENSATION DOCUMENT ORGANIZATION

DESCRIPTION

This Core Interoperability Specification describes the technical interface requirements that enable Healthcare Providers to record a medication dispensation to a patient in an outpatient environment or at the time of an in-patient discharge.

The Dispensation Record contains all information for the medication dispensed including active ingredient(s) as input for later drug interaction checking of new medication and lot/batch information needed for tracking purposes. This information is published and is accessible via the Health Information Exchange (HIE). This enables access to the information by various “edge” applications including Point of Service (PoS) systems and MOH business applications.

DOCUMENT CONVENTIONS

Requirements Numbering Conventions:

All Saudi eHealth Interoperability Specifications contain numbered requirements that follow this format:

- [ABCD-####], where ABCD is a three or four letter acronym unique to that Interoperability Specification for convenient purposes, and #### is the unique number for that requirement within the Interoperability Specification.
- Where a specific value set or code is required to be used, it can be found in the “IS0200 Saudi eHealth Terminology Repository”. The location and process to access the terminology repository will be specified in mechanisms external to this document.

Saudi eHealth numbered requirements are the elements of the Interoperability Specification that the system can claim conformance to. In other words, in order to implement a system that fully supports the Use Case and Interoperability Specification, the system shall be able to demonstrate that it conforms to every numbered requirement for the system actors to which it is claiming conformance.

Please note that all Saudi eHealth numbered requirements are numbered uniquely, however numbered requirements are not always sequential.

Requirements Language

Throughout this document the following conventions¹ are used to specify requirement levels:

SHALL: the definition is an absolute requirement of the specification. (Note: “SHALL IF KNOWN” means that the tag must be sent. However, if there were no information, then this tag should be sent with a <nullflavor>).

SHALL NOT: the definition is an absolute prohibition of the specification.

SHOULD: there may exist valid reasons in particular circumstances to ignore a particular item, but the full implications must be understood and carefully weighed before choosing a different course.

¹ Definitions based upon RFC 2119

SHOULD NOT: there may exist valid reasons in particular circumstances when the particular behavior is acceptable or even useful, but the full implications should be understood and the case carefully weighed before implementing any behavior described with this label.

MAY or **OPTIONAL:** means that an item is truly optional. One vendor may choose to include the item because a particular marketplace requires it or because the vendor feels that it enhances the product while another vendor may omit the same item.

METHODOLOGY

This Interoperability Specification has been developed with input from various Saudi stakeholders collected during several months through workshops and teleconferences. Stakeholders included Pharmacist, Physicians and Saudi eHealth IT specialists.

The development of a Core Interoperability Specification relies on the high-level requirements set by the associated Use Case. These high-level requirements are not restated in this specification and readers should review UC0008 *Saudi eHealth Medication Interoperability Use Case* document.

1. USE CASE OVERVIEW

This section provides an overview of the Dispensation Use Case. For full details of the Use Case see UC0008 *Saudi eHealth Medication Interoperability Use Case*

This section describes the underlying Use Case, including all design constraints and assumptions as well as the flows of information that will be specified in this specification. This section also introduces the scenarios that describe how the specified workflows may be used in the Saudi eHealth context.

1.1 SCOPE

In Scope:

The scope of this document is the specification of recording medication dispensations to a patient in an outpatient environment or at the time of an in-patient discharge. The Dispensation Record contains all information for the medication dispensed including active ingredient(s) as input for later drug interaction checking of new medication and lot/batch information needed for tracking purposes.

The following topics are in scope for this Interoperability Specification:

- Dispensation Records and their electronic documentation.
- Managing Dispensation Records.
- Content definitions of Dispensation Records.
- Medication dispensation at in-patient discharge.

Out of Scope:

The following is a list of content and specifications that are specifically out of scope for this Interoperability Specification:

- Content definition of the medication list section of the Interoperable Electronic Health Record (iEHR) summary.
- In-patient dispensation and medication management.
- The reconciliation of temporary KSA-Wide Health IDs to a patient's permanent KSA-Wide Health ID.
- Requirements for the User Interface for querying and retrieving Dispensations.
- Requirements for the User Interface for the display of the Dispensations.
- Requirements for the internal documentation of dispensations within a specific Healthcare Organization.

1.2 USE CASE ACTORS AND SERVICES

The Use Case Actors and the Services that are used by this Saudi eHealth eDispensation Interoperability Specification are described at a functional level in UC0008 *Saudi eHealth Medication Interoperability Use Case*. Readers who wish to understand the mapping of Use Case Actors to real world products are recommended to read UC0008 *Saudi eHealth Medication Interoperability Use Case*. A summary is provided in the following tables:

TABLE 1.2-1 USE CASE ACTORS

ACTOR NAME	DESCRIPTION
Dispenser	Responsible for the creation of Dispensation Records and publishing them to the HIE Document Repository.
HIE Document Repository	Stores Medication records (Prescription Records, Dispensation Records, and updates to such records) and performs Medication Interaction Checking. It also provides access to related information about patients and their medical records (e.g. allergies, lab results, etc.).

How actual implementations support Use Case Actors may vary. For example, some implementations may support a Use Case Actor entirely by a single system design. Other implementations may support a Use Case Actor using a gateway system integrated with the point of service system.

The typical implementation architecture aligns the Use Case Actor's capabilities as defined in this Core Interoperability Specification with a single system or integrated set of systems under the design and responsibility of one vendor.

In specific implementation situations the vendor boundary does not align with the Use Case Actor. For example, a point of service system is from one vendor, while a gateway system which converts the point of service system to the Use Case Actor is from a different vendor. The interface between the two systems is not specified by this Core Interoperability Specification and is the responsibility of the implementation project.

TABLE 1.2-2 USE CASE SERVICES

SERVICE NAME	DESCRIPTION
Create/Manage Dispensation	Used to create a Dispensation Record and publish it to the HIE Document Repository as well as to submit changes to a Dispensation Record (e.g. to stop intake of a Dispensation Item, to change dosage of a Dispensation Item, etc.).
Query/Retrieve Medication Records	Queries and retrieves relevant Medication Records and all related records (e.g., updates) from the HIE Document Repository.

1.3 DESIGN CONSTRAINTS AND ASSUMPTIONS

The following design principles underlie this interoperability specification:

- It is expected that all services initiated or provided by these Actors operate in accordance to the IS0303 *Saudi Health Information Exchange Polices*.

- Temporary KSA-Wide Health IDs can be created to enable the recording of Dispensation.
- A permanent KSA-Wide Health ID can be created for a newborn.
- It is the responsibility of the receiving system (Dispenser) to reconcile their local patient IDs and any other coded data elements with the KSA-Wide Health ID, and nationally specified coded data as well as other coded information in the dispensation.
- Along with the Dispensation document, a set of required metadata has to be created by the Dispenser and recorded in the HIE Document Repository in order to allow the Prescriber/Dispenser Actor in the receiving systems to select relevant clinical documents.

2. CORE INTEROPERABILITY SPECIFICATION REQUIREMENTS

2.1 ACTOR MAPPING TO SAUDI EHEALTH INTEROPERABILITY SPECIFICATIONS

A system conforming to this Core Interoperability Specification shall claim conformance at the level of a Use Case Actor. A system may claim conformance to one or more Use Case Actors. Multiple systems may fulfill a single Use Case Actor.

The Use Case Actors and the Services they support are described at a functional level in the UC0008 *Saudi eHealth Medication Interoperability Use Case*. Services may be required, conditional or optional. The Use Case Actors, Service(s) and Optionality are conveyed in the first three columns of Interoperability Conformance Requirement tables shown below.

The second part of the table (columns 4-7) provides the mapping for the Use Case Actor to the detailed specifications (such as IHE Profiles, Technical Actors, Optionality) that systems shall implement to exchange healthcare information in the context of this Use Case.

For a selected Use Case Actor (a single row in the table), all the requirements listed in the second part of the table (columns 4-7) shall be implemented. This includes the referenced profiles and the standards specified (terminology or other). For each Technical Actor (whether required or optional), the last column references the detailed specification that constrain and extend of the implementation of this profile for KSA specific requirements. These specifications may be found in Sections in this core specification or in other referenced Saudi eHealth Interoperability Specifications (e.g. Saudi eHealth Security and Privacy Interoperability Specification, etc.).

TABLE 2.1-1 INTEROPERABILITY CONFORMANCE REQUIREMENTS FOR DISPENSER

E-DISPENSATION			MAPPING TO TECHNICAL DOCUMENTS OF SAUDI EHEALTH INTEROPERABILITY SPECIFICATIONS			
USE CASE ACTOR	SERVICE SUPPORTED	OPT	TECHNICAL ACTOR	OPT	PROFILE/ STANDARD	REFERENCED SPECIFICATION
Dispenser	Create/Manage Dispensation	R	Medication Dispenser (grouped with Medication Interaction Reporter Actor)	R	IHE - Community Medication Prescription and Dispense (CMPD)	Sections 4.1.1 and 4.1.4 IS0200 Saudi eHealth Terminology Repository
			Content Creator	R	IHE – Pharmacy Dispense (DIS)	IS0106 Saudi eHealth Clinical Documents Constrains Interoperability Specification – Section 5.7 IS0200 Saudi eHealth Terminology Repository
			Pharmaceutical Adviser (grouped with a Medication Interaction Reporter Actor)	R	IHE - Community Medication Prescription and Dispense (CMPD)	Sections 4.1.2 and 4.1.4 IS0200 Saudi eHealth Terminology Repository

E-DISPENSATION			MAPPING TO TECHNICAL DOCUMENTS OF SAUDI EHEALTH INTEROPERABILITY SPECIFICATIONS			
			Content Creator	R	IHE – Pharmacy Pharmaceutical Advice (PADV)	IS0106 Saudi eHealth Clinical Documents Constrains Interoperability Specifications – Section 5.8 IS0200 Saudi eHealth Terminology Repository
			Document Source (grouped with Document Administrator Actor)	R	IHE – Cross-Enterprise Document Sharing (XDS.b)	IS0102 Saudi eHealth Document Sharing Interoperability Specification – Section 3.2 IS0200 Saudi eHealth Terminology Repository
			Secure Node	R	IHE Audit Trail and Node Authentication (ATNA)	IS0101 Saudi eHealth Security and Privacy Interoperability Specification – Section 3.2 and 3.3.2
			Time Client	R	IHE Consistent Time (CT)	IS0101 Saudi eHealth Security and Privacy Interoperability Specification – Section 3.1.2
	Query/Retrieve Medication Records	R	Medication Dispenser	R	IHE - Community Medication Prescription and Dispense (CMPD)	Section 4.1.3 IS0200 Saudi eHealth Terminology Repository
			Content Consumer	R	IHE – Pharmacy Dispense (DIS)	IS0106 Saudi eHealth Clinical Documents Constrains Interoperability Specifications – Section 5.7 IS0200 Saudi eHealth Terminology Repository
			Content Consumer	R	IHE – Pharmacy Prescription (PRE)	IS0106 Saudi eHealth Clinical Documents Constrains Interoperability Specifications – Section 5.6 IS0200 Saudi eHealth Terminology Repository
			Content Consumer	R	IHE – Pharmacy Pharmaceutical Advice (PADV)	IS0106 Saudi eHealth Clinical Documents Constrains Interoperability Specifications – Section 5.8 IS0200 Saudi eHealth Terminology Repository

E-DISPENSATION			MAPPING TO TECHNICAL DOCUMENTS OF SAUDI EHEALTH INTEROPERABILITY SPECIFICATIONS			
			Document Consumer	R	IHE – Cross-Enterprise Document Sharing (XDS.b)	IS0102 Saudi eHealth Document Sharing Interoperability Specification – Section 3.3 IS0200 Saudi eHealth Terminology Repository
			X-Service User	R	IHE – Cross-Enterprise User Assertion (XUA)	IS0101 Saudi eHealth Security and Privacy Interoperability Specification – Section 3.4.1
			Secure Node	R	IHE Audit Trail and Node Authentication (ATNA)	IS0101 Saudi eHealth Security and Privacy Interoperability Specification – Section 3.2 and 3.3.2
			Time Client	R	IHE Consistent Time (CT)	IS0101 Saudi eHealth Security and Privacy Interoperability Specification – Section 3.1.2
Dispenser (grouped with Clinical Content Consumer)	iEHR On-demand summary	R	NA	NA	NA	IS0007 Saudi eHealth Core Interoperability Specification for Clinical Notes and Summaries – Sections 3.4 and 4.3

TABLE 2.1-2 INTEROPERABILITY CONFORMANCE REQUIREMENTS FOR HIE DOCUMENT REPOSITORY

E-DISPENSATION			MAPPING TO TECHNICAL DOCUMENTS OF SAUDI EHEALTH INTEROPERABILITY SPECIFICATIONS			
USE CASE ACTOR	SERVICE SUPPORTED	OPT	TECHNICAL ACTOR	OPT	PROFILE/ STANDARD	REFERENCED SPECIFICATION AND COMMENTS
HIE Document Repository	Create/Manage Dispensation	R	Document Repository (grouped with Medication Interaction Checking Actor)	R	IHE – Cross-Enterprise Document Sharing (XDS.b)	Section 4.2.2 IS0102 Saudi eHealth Document Sharing Interoperability Specification – Section 3.4 IS0200 Saudi eHealth Terminology Repository
			Secure Node	R	IHE Audit Trail and Node Authentication (ATNA)	IS0101 Saudi eHealth Security and Privacy Interoperability Specification – Section 3.2 and 3.3.1
			Time Client	R	IHE Consistent Time (CT)	IS0101 Saudi eHealth Security and Privacy Interoperability Specification – Section 3.1.2

E-DISPENSATION			MAPPING TO TECHNICAL DOCUMENTS OF SAUDI EHEALTH INTEROPERABILITY SPECIFICATIONS			
USE CASE ACTOR	SERVICE SUPPORTED	OPT	TECHNICAL ACTOR	OPT	PROFILE/ STANDARD	REFERENCED SPECIFICATION AND COMMENTS
	Query/Retrieve Medication Records	R	Community Pharmacy Manager	R	IHE - Community Medication Prescription and Dispense (CMPD)	Section 4.2.1 IS0200 Saudi eHealth Terminology Repository
			Document Registry and Document Repository	R	IHE – Cross-Enterprise Document Sharing (XDS.b)	IS0102 Saudi eHealth Document Sharing Interoperability Specification – Section 3.4 IS0200 Saudi eHealth Terminology Repository
			X-Service Provider	R	IHE – Cross-Enterprise User Assertion (XUA)	IS0101 Saudi eHealth Security and Privacy Interoperability Specification – Section 3.4.2
			Secure Node	R	IHE Audit Trail and Node Authentication (ATNA)	IS0101 Saudi eHealth Security and Privacy Interoperability Specification – Section 3.2 and 3.3.1
			Time Client	R	IHE Consistent Time (CT)	IS0101 Saudi eHealth Security and Privacy Interoperability Specification – Section 3.1.2

R=Required, O = Optional, C= Conditional

2.2 INTEROPERABILITY SEQUENCE DIAGRAMS

The following Sequence diagrams provide an overview of the combined flow of transactions resulting from the above selected profiles and standards. The Main Flow Sequence Diagram illustrates a very common (i.e., typical) workflow and other sequence diagrams are shown to provide an alternative or exception to the main flow. Other sequence diagrams are possible but they cover the same key transactions with only slight variants of information exchange between the Use Case Actors, therefore, have been omitted.

The eDispensation sequence diagrams provide a high level sequence of events for the exchange of information for recording medication dispensation. It also illustrates typical security exchanges for authorized network communications and audit trail of patient information access.

There are two Main Flow one Alternative and two Exception Sequence Diagrams. In addition, a number of pre-conditions and other requirements exist

2.2.1 Sequence Diagram Pre-conditions

A number of pre-conditions must exist in order to enable the main, alternative and exception sequence diagrams.

1. Prior to retrieving documents from the HIE Document Repository or creating documents to share on the HIE Document Repository; the Healthcare Provider or Organization **SHALL** obtain the KSA-Wide Health ID. The requirements on how to obtain a patient's KSA-Wide Health ID and key patient demographics are defined in IS0001 *Saudi eHealth Core Interoperability Specification for KSA-Wide Patient Demographic Query*. The Health ID and key patient demographics attributes are used to identify the patient for which the prescriptions and medications are shared. This ensures KSA-Wide identification of the patient in health records. This is not shown in any of the sequence diagrams, and the details to accomplish this are defined in IS0001 *Saudi eHealth Core Interoperability Specification for KSA-Wide Patient Demographic Query*.
2. The [IHE XDS.b: Register Document Set – b ITI-42] transaction is listed without first performing the authentication between the Document Repository and Registry Systems [IHE ATNA Profile: Authenticate Node ITI-19]. This is because it is very common that those two systems are implemented within the same system. If these Actors are implemented in separate systems the authentication transaction would be required.
3. When querying and retrieving medication documents, the [IHE CMPD Profile: Query Pharmacy Documents PHARM-1] and [IHE XDS-b: Retrieve Document Set ITI-43] transitions are listed without first performing the authentication between the two systems (e.g. an edge system and the HIE Document Repository) [IHE ATNA Profile: Authenticate Node ITI-19]. The IHE ATNA transaction is required to be performed.

The following transactions must occur prior to the start of the main, alternative or exception Sequences:

1. Time synchronization **SHALL** occur at least once prior to communicating between the HIE Document Repository and the Dispenser.
2. Before the information exchanges can take place, an authentication process takes place between the Dispenser/Secure Node Actor and the HIE Document Repository/Secure Node Actor occurs [IHE ATNA Profile: Authenticate Node ITI-19].

Note: It is assumed that once a secure connection has been established, it will be maintained. If this is not the case, then an additional authentication transaction will need to occur before continuing any exchange transactions.

Figure 2.2-1 Pre-condition sequence diagram depicts the pre-condition in the case that the Dispenser is acting as a Medication Dispenser.

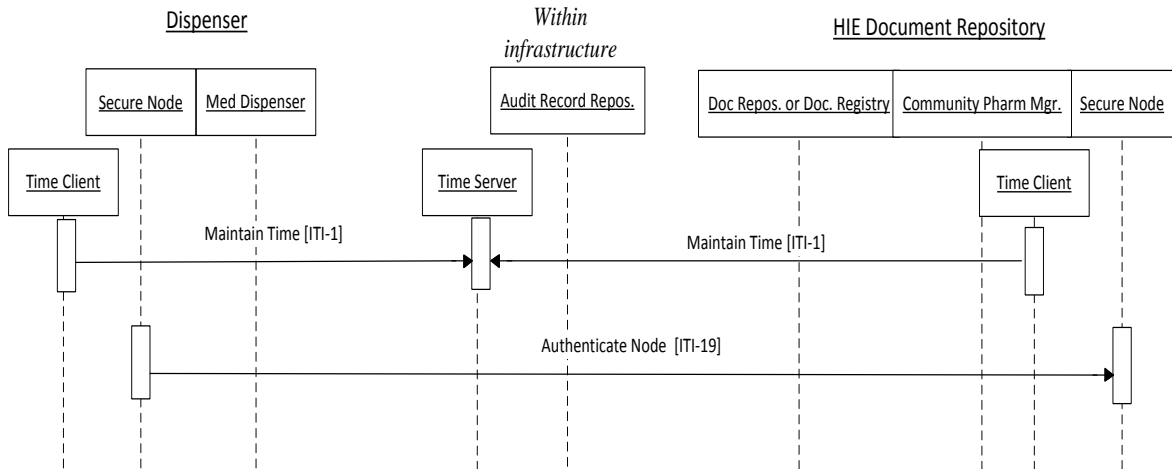

FIGURE 2.2-1 PRE-CONDITION SEQUENCE DIAGRAM

2.2.2 Other Sequence Diagram Requirements

In order to simplify the sequence diagrams, the following transaction pairings should be taken into account.

2.2.2.1 Publish Medication Document(s) to the HIE Document Repository

Figure 2.2.2-2 Transactions associated with Publish Medication Document and the text below depict the transactions associated with storage of medication document(s) (i.e. Dispensation Records, Update Records, and Medication Interaction Checking Issue Management Records) to the HIE Document Repository. When document(s) are stored to the Document Repository, the following transactions must all take place:

1. The Dispenser/Document Source publishes the medication document to the HIE Document Repository/Document Repository using [IHE XDS.b: Provide & Register Document Set ITI-41].
2. The Dispenser/Secure Node generates a local audit record of the release of patient health information [using the data content as defined by IHE ATNA and IHE XDS.b Profiles].
3. The HIE Document Repository registers the medication document with the Document Registry [IHE XDS.b: Register Document Set – b ITI-42].
4. The HIE Document Repository/Secure Node generates an audit record of the receipt of patient health information [IHE ATNA Profile: Record Audit Event ITI-20].

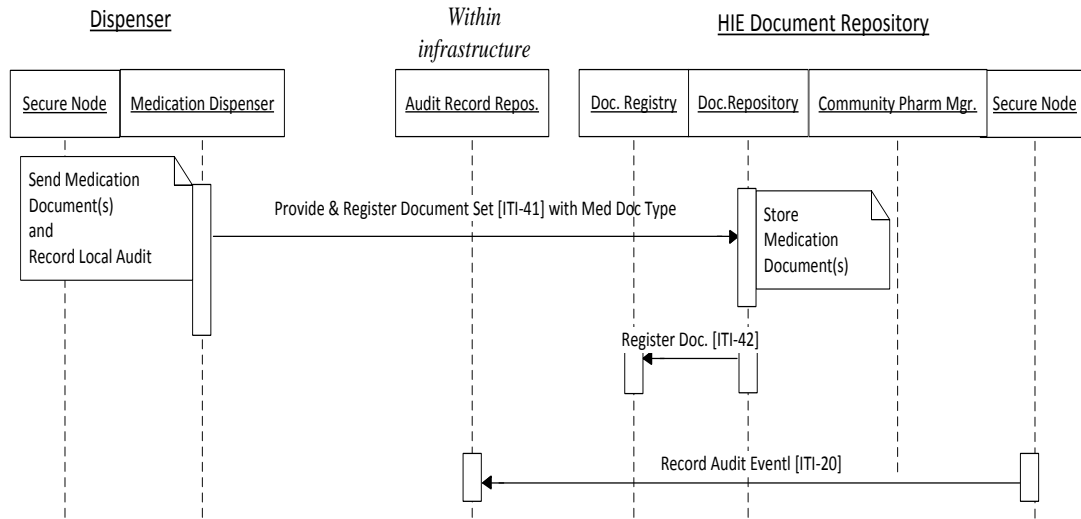

FIGURE 2.2.2-2 TRANSACTIONS ASSOCIATED WITH PUBLISH MEDICATION DOCUMENT

2.2.2.2 Query/Retrieve Medication Documents from the HIE Document Repository

The Query/Retrieve Medication sequence flow diagram and the text below depict querying and retrieving Dispensation and Prescription Records and all related records (e.g., updates) from the HIE Document Repository.

The main flows for querying and retrieving medication records are:

- Query Dispensation or Prescription Records from the HIE Document Repository.
- Identify the Dispensation or Prescription Records in the search result.
- Retrieve the Dispensation or Prescription Records and all related records from the HIE Document Repository and processing them (i.e., apply to each dispensation or prescription the updates from related pharmaceutical advices to present the most current view).

Figure 2.2.2-3 Transactions associated with Query/Retrieve Medication Documents and the text below depict the steps for querying for medication documents.

The ability to query/retrieve medication documents is needed for those who create prescriptions and those who dispense medications. Therefore, the Dispenser and Prescriber Use Case Actors need to support this workflow. When a query/retrieve is made from the Dispenser or Prescriber Actor to the HIE Document Repository Actor, the following transactions **SHALL** all take place.

1. The Dispenser/X-Service User or Prescriber/X-Service User sends a query request to the HIE Document Repository/Community Pharmacy Manager. As part of the query request, a user assertion is conveyed to verify that the Healthcare Provider or Organization is an authorized user to obtain patient information [IHE CMPD: Query Pharmacy Documents PHARM-1] [using any of the FindPrescriptions, FindPrescriptionsForDispense or FindDispenses query] and [IHE XUA: Provide X-User Assertion ITI-40].

The Dispenser/Secure Node or Prescriber/Secure Node generates a local audit record of the access to patient health information [using the data content as defined by IHE ATNA and IHE CMPD Profiles].

2. The HIE Document Repository/Secure Node generates an audit record of the receipt of patient health information [IHE ATNA Profile: Record Audit Event ITI-20].
3. The Dispenser/X-Service User or Prescriber/X-Service User retrieves the medication document(s) of interest. As part of the retrieve, a user assertion is conveyed to verify that the Healthcare Provider or Organization is an authorized user to obtain patient information [IHE XDS-b: Retrieve Document Set ITI-43] and [IHE XUA: Provide X-User Assertion ITI-40].

The Dispenser/Secure Node or Prescriber/Secure Node generates a local audit record of the access to patient health information [using the data content as defined by IHE ATNA and IHE XDS.b Profiles].

4. The HIE Document Repository/Secure Node generates an audit record of the access to patient health information [IHE ATNA Profile: Record Audit Event ITI-20].
5. The medication documents are available for review.

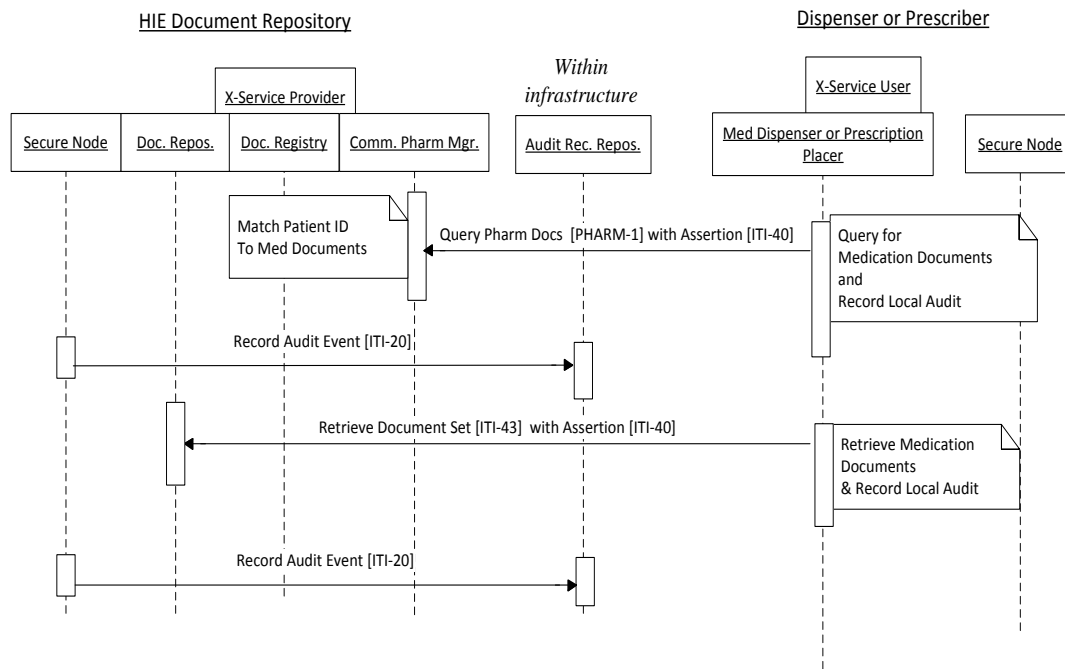

FIGURE 2.2.2-3 TRANSACTIONS ASSOCIATED WITH QUERY/RETRIEVE MEDICATION DOCUMENTS

2.2.2.3 iEHR On-Demand Summary

In order to obtain the patient's summary record, the Interoperable Electronic Health Record (iEHR) summaries containing clinical data from all of the patient's visits since the last patient visit are queried and retrieved using the Clinical Content Consumer Actor. This is called iEHR On-Demand Summary.

The Dispenser Actor is grouped with the Clinical Content Consumer Actor to obtain the iEHR on-demand summary document. The requirements on how to obtain the iEHR summary are defined in the IS0007 *Saudi eHealth Core Interoperability Specification Clinical Notes and Summaries* document.

Example usage of the iEHR Summary:

- Review patient's current medication list.
- Perform medication reconciliation (e.g. systematic evaluation of a patient's complete medication regime including information about Immunizations and Allergies).

2.2.3 Main Flow Sequence Diagram – Paper Prescription or Over The Counter (OTC) Medication

The main flow sequence diagram and the text below depict documenting the dispensation of medication to a patient. The patient either has a paper prescription (i.e. no electronic prescription is available) to be filled or is obtaining an over the counter drug (i.e., the workflow is the same for both scenarios).

The main flows are:

- Obtaining the patient's medication history and possibility of performing medication reconciliation.
- Submission of the Dispensation Record to the HIE Document Repository.
- HIE Document Repository performs Medication Interaction Checking with no errors.

Note: If issues are discovered during Medication Interaction Checking, this results either in a change of the Dispensation or in the acceptance of the issues by the Healthcare Provider (this scenario will be addressed in the Exception flow sequence diagram).

Note: The Use Case Services are actually implemented using the underlying transaction(s) defined by the Profiles or Standards selected. Therefore, the Use Case Services are not depicted directly in the sequence diagrams.

Steps 1 – 5 related to the dispensation of medication are shown in Figure 2.2.3-4 Transactions associated with Dispense medication – Paper Prescription or OTC.

1. The patient visits a Healthcare Provider or Organization to obtain medication. The patient's KSA-Wide Health ID is obtained to access the patient's medical records. See pre-conditions described in Section 2.2.1.
2. The Dispenser/Clinical Content Consumer Actor queries and retrieves the patient's iEHR On-Demand Summary document from the HIE Document Repository. The Healthcare Provider **MAY** perform Medication Reconciliation. Obtaining the iEHR On-Demand Summary is described in Section 2.2.2.3.
3. The dispensation is recorded in the local Point of Service system and a Dispensation Record is created. The Dispenser/Medication Dispenser Actor publishes the Dispensation Record [IHE XDS.b: Provide & Register Document Set ITI-41] to the HIE Document Repository (see Section 2.2.2.1 Publish Documents for the full set of transactions).
4. The HIE Document Repository performs Medication Interaction Checking based upon the Dispensation Record. No issues are found and the Dispensation Record is successfully published to the HIE Document Repository with no errors.
5. The Healthcare Provider dispenses the medication to the patient.

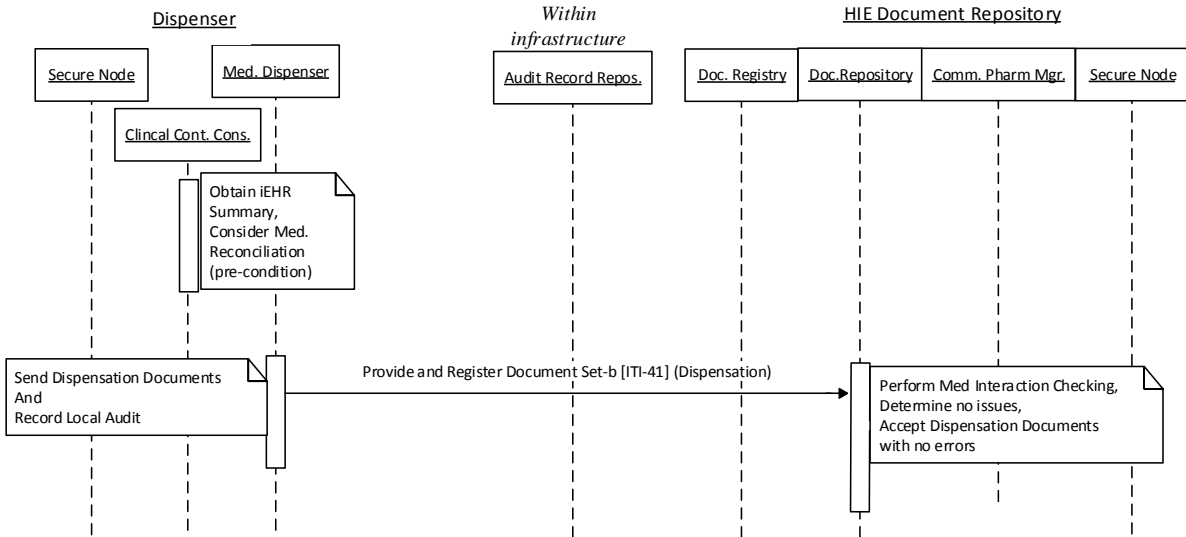

FIGURE 2.2.3-4 TRANSACTIONS ASSOCIATED WITH DISPENSE MEDICATION – PAPER PRESCRIPTION OR OTC

2.2.4 Main Flow Sequence Diagram – ePrescription Available

The main flow sequence diagram and the text below depict the dispensation of medication to a patient with an ePrescription.

The main flows are:

- Obtain the patient’s open prescriptions, medication history and possibly perform medication reconciliation.
- Submit the Dispensation Record to the HIE Document Repository.
- The HIE Document Repository performs Medication Interaction Checking with no errors or informational issues only.

Note: If issues are discovered during the Medication Interaction Checking, this results either in a change of the Dispensation or in the acceptance of the issues by the Healthcare Provider (this scenario will be addressed in the Exception flow sequence diagram).

Note: The Use Case Services are actually implemented using the underlying transaction(s) defined by the Profiles or Standards selected. Therefore, the Use Case Services are not depicted directly in the sequence diagrams.

Steps 1 – 6 related to the dispensation of medication are shown in Figure 2.2.4-5 Transactions associated with Dispense Medication – ePrescription available.

1. The patient visits a Healthcare Provider or Organization to obtain medication. The patient’s KSA-Wide Health ID is obtained to access the patient’s medical records. See pre-conditions described in Section 2.2.1.
2. The Dispenser/Medication Dispenser Actor queries and retrieves the patient’s ePrescription(s). This process is described in Section 2.2.2.2.
3. The Dispenser/Clinical Content Consumer Actor queries and retrieves the patient’s iEHR On-Demand Summary document from the HIE Document Repository. The Healthcare

Provider **MAY** perform Medication Reconciliation. Obtaining the iEHR on-demand summary is described in Section 2.2.2.3.

4. The dispensation is recorded in the local Point of Service system and a Dispensation Record is created for each dispensed Prescription Item on the ePrescription, each containing a reference to the Prescription Item it relates to. The Dispenser/Medication Dispenser Actor publishes the Dispensation Record(s) [IHE XDS.b: Provide & Register Document Set ITI-41] to the HIE Document Repository. See Section 2.2.2.1 Publish Documents for the full set of transactions.
5. The HIE Document Repository performs a Medication Interaction Checking service based upon the Dispensation Record(s). No issues are found and the Dispensation Record(s) are successfully published to the HIE Document Repository with no errors.

Note: The Medication Interaction Checking service may also respond with “informational text”. This does not change the sequence flow as it is considered a successful response.

6. The Healthcare Provider dispenses the medication to the patient.

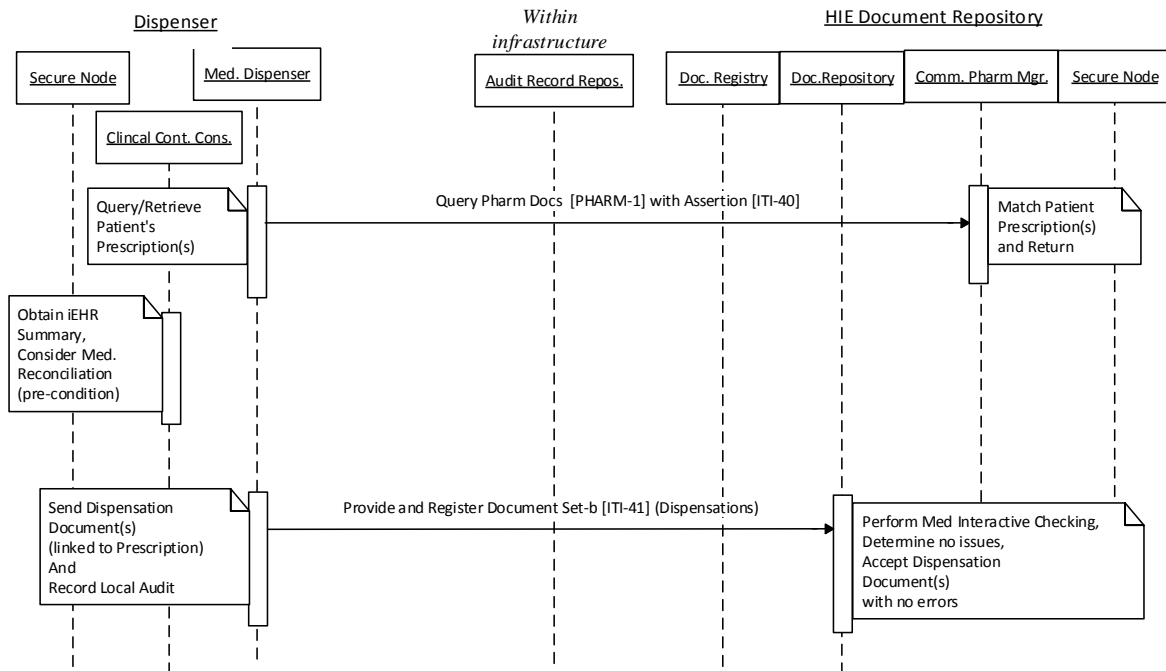

FIGURE 2.2.4-5 TRANSACTIONS ASSOCIATED WITH DISPENSE MEDICATION – EPRESCRIPTION AVAILABLE

2.2.5 Alternate Flow Sequence Diagram – Manage Dispensation Record

The alternate flow sequence diagram and the text below depict managing the Dispensation Record by making changes such as:

- Change dosing of Dispensation Item.
- Stop intake of Dispensation Item.
- Set Dispensation Item to suspend.
- Set Dispensation Item to active.

The alternate flows are:

- Manage the Dispensation Item in the local system.
- Local Point of Service system creates the update to the Dispensation Record.
- Submit the update to the HIE Document Repository.

Note: The Use Case Services are actually implemented using the underlying transaction(s) defined by the Profiles or Standards selected. Therefore, the Use Case Services are not depicted directly in the sequence diagrams.

Steps 1 – 2 related to the management of a Dispensation Records are shown in Figure 2.2.5-6 Transactions associated with managing the Dispensation Record.

1. The update to the Dispensation Record is recorded in the local Point of Service system and an Update Record (see IS0106 *Common Constraints for Clinical Documents Interoperability Specification* – Section 5.8) is created containing a reference to the Dispensation Record. The Dispenser/Medication Dispenser Actor publishes the Update Record [IHE XDS.b: Provide & Register Document Set ITI-41] to the HIE Document Repository. See Section 2.2.2.1 Publish Documents for the full set of transactions.
2. The HIE Document Repository performs a Medication Interaction Checking service based upon the updated Dispensation Record. No issues are found and the Update Record is successfully published to the HIE Document Repository with no errors.

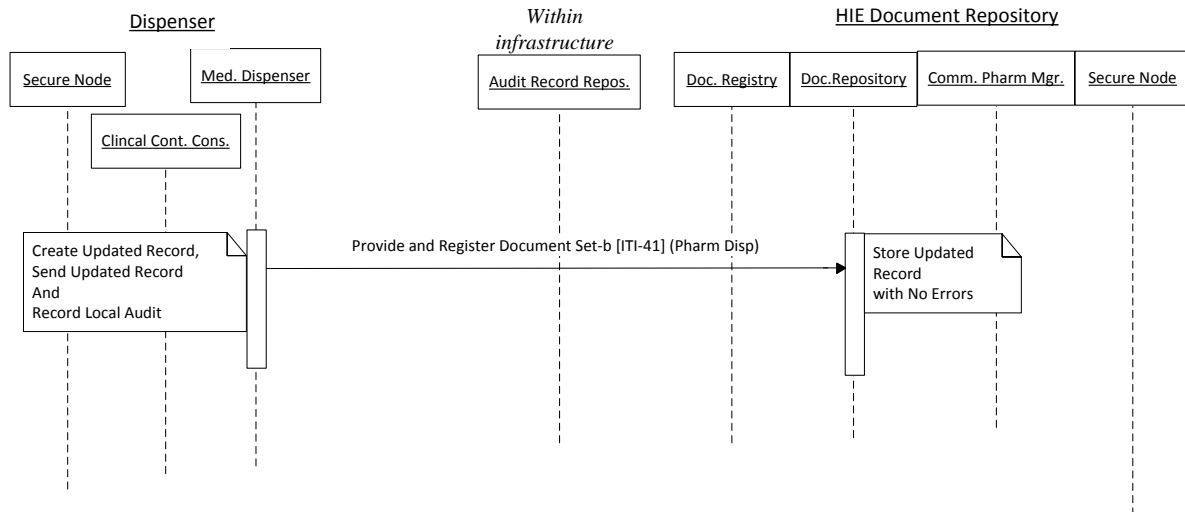

FIGURE 2.2.5-6 TRANSACTIONS ASSOCIATED WITH MANAGING THE DISPENSATION RECORD

2.2.6 Exception Flow Sequence Diagram – Medication Interaction Checking Determines Errors or Warnings

The exception flow sequence diagram and the text below depict the dispensation of medication to a patient with the Medication Interaction Checking service finding errors.

The exception flows are based on the main flow with the following differences:

- At submission of the Dispensation Record, the HIE Document Repository performs Medication Interaction Checking which determines errors or warnings.

- After the Healthcare Provider examines the issues, the Prescription is either changed or the issue is accepted. If the Healthcare Provider accepts the issues, Issue Management Record(s) are created to document the reason(s) why the issues are accepted.
- The same or updated Dispensation Record is submitted with a Medication Interaction Checking Issue Management Record to document the reasons for dispensing the medication.
- The HIE Document Repository performs Medication Interaction Checking which determines errors or warnings, which the HIE Document Repository now identifies as accepted by the Healthcare Provider (via the Issue Management Records). Thus the Dispensation Record is successfully published to the HIE Document Repository with no errors.

Note: The Use Case Services are actually implemented using the underlying transaction(s) defined by the Profiles or Standards selected. Therefore, the Use Case Services are not depicted directly in the sequence diagrams.

Steps 1 – 4 are identical to Steps 1 – 4 of the main flow sequence (see Section 2.2.4 Main flow sequence diagram – ePrescription available) and are not shown in this diagram.

Steps 5 – 8 related to the dispensation of medication are shown in Figure 2.2.6-7 Transactions associated with Dispense medication – Medication Interaction Checking with errors or warnings.

5. The HIE Document Repository performs Medication Interaction Checking based upon the Dispensation Record. One or more issues of class “Error” or “Warning” are found and the Dispensation Record is rejected with specified Medication Interaction Checking error codes are returned for each issue found.
6. The Healthcare Provider reviews the Medication Interaction Checking Issues contained in the error code information and decides to accept the issues (i.e., medication should still be dispensed to the patient). The reasons for dispensing the medication are recorded in the local Point of Service system and Medication Interaction Checking Issue Management Record(s) are created (see IS0106 *Common Constraints for Clinical Documents Interoperability Specification* – Section 5.8). The Dispenser/Medication Dispenser Actor publishes the same or updated Dispensation Record and the Issue Management Record together using [IHE XDS.b: Provide & Register Document Set ITI-41] to the HIE Document Repository. See Section 2.2.2.1 Publish Medication Documents for the full set of transactions.
7. The HIE Document Repository performs a Medication Interaction Checking service based upon the Dispensation Record. One or more issues of class “Error” or “Warning” are found, which the HIE Document Repository now can successfully map to related Medication Interaction Checking Issue Management Records. Thus the Dispensation and all related Medication Interaction Checking Issue Management Records are successfully published to the HIE Document Repository with no errors.
8. The Healthcare Provider dispenses the medication to the patient.

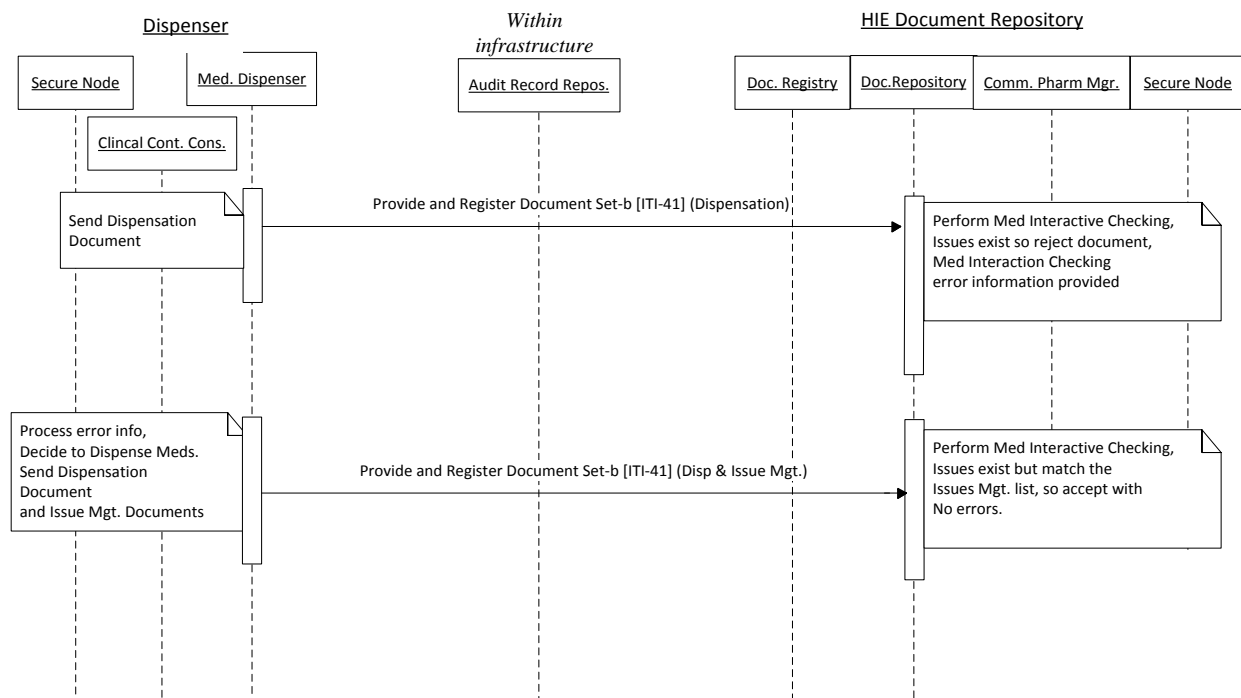

FIGURE 2.2.6-7 TRANSACTIONS ASSOCIATED WITH DISPENSE MEDICATION – MEDICATION INTERACTION CHECKING WITH ERRORS OR WARNINGS

2.2.7 Exception Flow – Revoke Dispensation Record

The exception flow sequence diagram and the text below depict revoking the dispensation of medication already submitted to the HIE Document Repository (e.g., in case of error).

The exception flows are based on the main flow with the following differences:

- After submitting the Dispensation Record to the HIE Document Repository, the Healthcare Provider decides to revoke the dispensation in the local Point of Service system.
- The Healthcare Provider sends a request to the HIE Document Repository which then deletes the Dispensation Record.

Steps 1 – 4 are identical to Steps 1 – 4 of the main flow sequence (see Section 2.2.4 Main flow sequence diagram – ePrescription available) and are not shown in this diagram.

Steps 5 – 6 related to the revoking of dispensations are shown in Figure 2.2.5-6 Transactions associated with managing the Dispensation Record.

5. The Healthcare Provider decides to revoke a dispensation in the local Point of Service system and HIE Document Repository due to an error. The Dispenser/Medication Dispenser Actor deletes the Dispensation Record [IHE XDS.b Supplement: Metadata Update: Delete Document Set Request ITI-62] in the HIE Document Repository (see Section 4.1.1 for the constraints on deleting dispensations).

6. The Healthcare Provider revokes the dispensation.

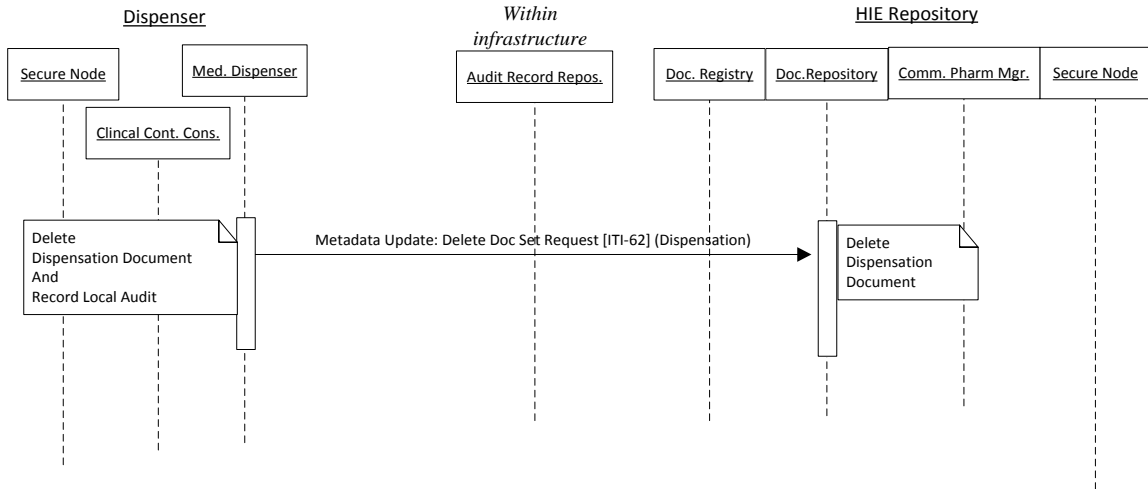

FIGURE 2.2.7-8 TRANSACTIONS ASSOCIATED WITH REVOKING A DISPENSATION RECORD

3. EDISPENSATION ACTOR CONFORMANCE

This section is designed to establish the Conformance Requirements for the Interoperability Specification. It maps one to one, with the table in section 2.1.

3.1 DISPENSER CONFORMANCE

Systems may claim conformance to the IS0009 *Saudi eHealth Core Interoperability Specification for eDispensation* as a Dispenser as follows:

“eDispensation Dispenser Actor”

This requires:

- supporting the Create/Manage Dispensation Service by conforming to:

[KDIS-001] – IHE - Community Medication Prescription and Dispense (CMPD) as a Medication Dispenser Actor (grouped with the Medication Interaction Checking Reporter Actor) with the additional constraints specified in:

- Sections 4.1.1 and 4.1.4
- *IS0200 Saudi eHealth Terminology Repository*

[KDIS-002] – IHE – Pharmacy Dispense (DIS) as a Content Creator Actor with the additional constraints specified in:

- *IS0106 Saudi eHealth Clinical Documents Constrains Interoperability Specifications - Section 5.7*
- *IS0200 Saudi eHealth Terminology Repository*

[KDIS-003] – IHE - Community Medication Prescription and Dispense (CMPD) as a Pharmaceutical Adviser Actor (grouped with the Medication Interaction Reporter Actor) with the additional constraints specified in:

- Sections 4.1.2 and 4.1.4
- *IS0200 Saudi eHealth Terminology Repository*

[KDIS-004] – IHE – Pharmacy Pharmaceutical Advice (PADV) as a Content Creator Actor with additional constraints specified in:

- *IS0106 Saudi eHealth Clinical Documents Constrains Interoperability Specifications - Section 5.8*
- *IS0200 Saudi eHealth Terminology Repository*

[KDIS-005] – IHE – Cross-Enterprise Document Sharing (XDS.b) Integration Profile as a Document Source Actor (grouped with a Document Administrator Actor) with the additional constraints specified in:

- *IS0102 Saudi eHealth Document Sharing Interoperability Specification – Section 3.2*
- *IS0200 Saudi eHealth Terminology Repository*

[KDIS-006] – IHE Audit Trail and Node Authentication (ATNA) Integration Profile as a Secure Node Actor with the additional constraints specified in:

- IS0101 *Saudi eHealth Security and Privacy Interoperability Specification* – Section 3.2 and 3.3.2

[KDIS-007] – IHE Consistent Time (CT) Integration Profile as a Time Client Actor with the additional constraints specified in:

- IS0101 *Saudi eHealth Security and Privacy Interoperability Specification* – Section 3.1.2

➤ supporting the Query/Retrieve Medication Records Service by conforming to:

[KDIS-008] – IHE – Community Medication Pharmacy Prescription and Dispense (CMPD) as a Medication Dispenser Actor with the additional constraints specified in:

- Section 4.1.3
- *IS0200 Saudi eHealth Terminology Repository*

[KDIS-009] – IHE – Pharmacy Dispense (DIS) as a Content Consumer Actor with the additional constraints specified in:

- *IS0106 Saudi eHealth Clinical Documents Constrains Interoperability Specifications* - Section 5.7
- *IS0200 Saudi eHealth Terminology Repository*

[KDIS-010] – IHE – Pharmacy Pharmaceutical Advice (PADV) as a Content Consumer Actor with additional constraints specified in:

- *IS0106 Saudi eHealth Clinical Documents Constrains Interoperability Specifications* - Section 5.8
- *IS0200 Saudi eHealth Terminology Repository*

[KDIS-011] – IHE – Pharmacy Prescription (PRE) as a Content Consumer Actor with additional constraints specified in:

- *IS0106 Saudi eHealth Clinical Documents Constrains Interoperability Specifications* - Section 5.6
- *IS0200 Saudi eHealth Terminology Repository*

[KDIS-012] – IHE – Cross-Enterprise Document Sharing (XDS.b) Integration Profile as a Document Consumer Actor with the additional constraints specified in:

- *IS0102 Saudi eHealth Document Sharing Interoperability Specification* – Section 3.3
- *IS0200 Saudi eHealth Terminology Repository*

[KDIS-013] – IHE Cross-Enterprise User Assertion (XUA) Integration Profile as an X-Service User Actor with the additional constraints specified in:

- IS0101 *Saudi eHealth Security and Privacy Interoperability Specification* – Section 3.4.1

[KDIS-014] – IHE Audit Trail and Node Authentication (ATNA) Integration Profile as a Secure Node Actor with the additional constraints specified in:

- IS0101 *Saudi eHealth Security and Privacy Interoperability Specification* – Section 3.2 and 3.3.2

[KDIS-015] – IHE Consistent Time (CT) Integration Profile as a Time Client Actor with the additional constraints specified in:

- IS0101 *Saudi eHealth Security and Privacy Interoperability Specification* – Section 3.1.2

➤ supporting the iEHR On-Demand Summary by conforming to:

[KDIS-016] – IS0007 *Saudi eHealth Core Interoperability Specification for Clinical Notes and Summaries*– Section 2.1 and 3.3. The Dispenser Actor is grouped with the Clinical Content Consumer Actor.

3.2 HIE DOCUMENT REPOSITORY CONFORMANCE

Systems may claim conformance to the IS0009 *Saudi eHealth Core Interoperability Specification for eDispensation* as an HIE Document Repository as follows:

“eDispensation HIE Document Repository Actor”

This requires:

➤ supporting the Create/Manage Dispensation Service by conforming to:

[KDIS-020] – IHE – Cross-Enterprise Document Sharing (XDS.b) as a Document Repository Actor (grouped with Medication Interaction Checking Actor) with additional constraints specified in:

- IS0102 *Saudi eHealth Document Sharing Interoperability Specification* – Section 3.4
- *IS0200 Saudi eHealth Terminology Repository*

[KDIS-021] – IHE Audit Trail and Node Authentication (ATNA) Integration Profile as a Secure Node Actor with the additional constraints specified in:

- IS0101 *Saudi eHealth Security and Privacy Interoperability Specification* – Section 3.2 and 3.3.1

[KDIS-022] – IHE Consistent Time (CT) Integration Profile as a Time Client Actor with the additional constraints specified in:

- IS0101 *Saudi eHealth Security and Privacy Interoperability Specification* – Section 3.1.2

➤ supporting the Query/Retrieve Medication Records Service by conforming to:

[KDIS-023] – IHE – Community Medication Pharmacy Prescription and Dispense (CMPD) as a Community Pharmacy Manager Actor with the additional constraints specified in:

- Section 4.2.1
- *IS0200 Saudi eHealth Terminology Repository*

[KDIS-024] – IHE – Cross-Enterprise Document Sharing (XDS.b) as a Document Registry and Document Repository Actor with the additional constraints specified in:

- IS0102 *Saudi eHealth Document Sharing Interoperability Specification* – Section 3.4
- *IS0200 Saudi eHealth Terminology Repository*

[KDIS-025] – IHE Cross-Enterprise User Assertion (XUA) Integration Profile as an X-Service User Actor with the additional constraints specified in:

- IS0101 *Saudi eHealth Security and Privacy Interoperability Specification* – Section 3.4.2

[KDIS-026] – IHE Audit Trail and Node Authentication (ATNA) Integration Profile as a Secure Node Actor with the additional constraints specified in:

- IS0101 *Saudi eHealth Security and Privacy Interoperability Specification* – Section 3.2 and 3.3.1

[KDIS-027] – IHE Consistent Time (CT) Integration Profile as a Time Client Actor with the additional constraints specified in:

- IS0101 *Saudi eHealth Security and Privacy Interoperability Specification* – Section 3.1.2

4. SAUDI EHEALTH CONSTRAINTS ON EDISPENSATION

This section defines required behavior rules for Use Case Actors defined in this Core Interoperability Specification.

4.1 REQUIREMENTS FOR DISPENSER USE CASE ACTOR

[KDIS-030] – The Dispenser Actor is grouped with the Clinical Content Consumer Actor to query an iEHR on-demand Summaries Documents based upon IS0007 *Saudi eHealth Core Interoperability Specificatio for Clinical Notes and Summaries* – Sections 2.1 and 3.3.

[KDIS-031] – A Dispenser Actor/Document Consumer **SHALL** be able to process and display the iEHR on-demand Summaries Documents as specified in IS0106 *Saudi eHealth Common Constraints for Clinical Documents Interoperability Specifications* – Section 5.5.

4.1.1 Medication Dispenser Technical Actor

The following rules shall be supported for the conformance to the Dispenser Actor as a Medication Dispenser Technical Actor (grouped with a Medication Interaction Checking Reporter Actor):

[KDIS-033] – A Medication Dispenser Actor **SHALL** publish Dispensation Documents with content as specified in IS0106 *Saudi eHealth Clinical Documents Constrains Interoperability Specifications* – Section 5.7.

[KDIS-034] – The XDS Metadata associated with creating a Dispensation Document is defined in two parts. The non-medication dispense specific metadata are specified in the document – IS0102 *Saudi eHealth Document Sharing Interoperability Specification* - Section 3.2.1. The Medication Dispense specific extensions **SHALL** meet the following additional constraints:

[KDIS-036] – The classCode attribute **SHALL** contain one coded value which **SHALL** be “DISPENSATIONS”.

[KDIS-037] – The practiceSetting attribute **SHALL** contain one coded value from the “KSA Organization Specialty”.

[KDIS-038] – The typeCode Attribute **SHALL** be set to “60593-1, LOINC, Medication Dispensed”.

[KDIS-039] – The mimeType attribute **SHALL** contain one coded value which **SHALL** be “text/xml” as described in the “MIME Type” value set.

[KDIS-040] – The formatCode attribute **SHALL** contain one coded value which **SHALL** be “urn:ihe:pharm:dis:2010” for the Pharmacy Dispense as described in the KSA Format Code value set.

[KDIS-042] – If a Dispensation Document has been published with an error, a Dispenser Actor (Document Source of the IHE-XDS Profile grouped with a Document Administrator Actor-See KXDS-072 in IS0102 *Saudi eHealth Document Sharing Interoperability Specification*) **SHALL** correct the error by using the [IHE XDS.b Supplement: Metadata

Update: Delete Document Set Request ITI-62] to delete the original Dispensation Document.

[KDIS-043] -- Dispensation Documents **SHALL NOT** be deleted, if related Pharmaceutical Advice Documents exist.

[KDIS-044] – When generating Dispensation Documents (as a Medication Dispenser Actor) and Pharmaceutical Advice Documents (as a Pharmaceutical Adviser Actor) as a result of Medication Interaction Checking Issue Management, the Dispenser Actor **SHALL** publish the documents to the HIE Document Repository using the same [IHE XDS.b: Provide & Register Document Set ITI-41] transaction.

4.1.2 Pharmaceutical Adviser Technical Actor

The following rules shall be supported for the conformance to the Dispenser Actor as a Pharmaceutical Adviser Technical Actor (grouped with a Medication Interaction Checking Reporter Actor):

[KDIS-047] – A Pharmaceutical Adviser Actor **SHALL** publish Pharmaceutical Advice Documents with content as specified in IS0106 *Saudi eHealth Clinical Documents Constrains Interoperability Specifications* – Section 5.8.

[KDIS-048] – The XDS Metadata associated with creating a Pharmaceutical Advice Document is defined in two parts. The non-pharmaceutical advice specific metadata are specified in the document – IS0102 *Saudi eHealth Document Sharing Interoperability Specification* - Section 3.2.1. The medication dispense specific extensions **SHALL** meet the following additional constraints:

[KDIS-049] – The classCode attribute **SHALL** contain one coded value which **SHALL** be “DISPENSATIONS”.

[KDIS-050] – The practiceSetting attribute **SHALL** contain one coded value from the “KSA Organization Specialty”.

[KDIS-051] – The typeCode Attribute **SHALL** be set to “61356-2, LOINC, Medication Pharmaceutical Advice”.

[KDIS-052] – The mimeType attribute shall contain one coded value which **SHALL** be “text/xml” as described in the “MIME Type” value set.

[KDIS-053] – The formatCode attribute **SHALL** contain one coded value which **SHALL** be “urn:ihe:pharm:padv:2010” for the Pharmacy Pharmaceutical Advice as described in the KSA Format Code value set..

4.1.3 Medication Dispenser or Prescription Placer Technical Actor Using the Query/Retrieve Medication Records Service

The following rules shall be supported for the conformance to the Medication Dispenser and Prescription Placer Actors when using the Query/Retrieve Medication Records Service.

[KDIS-056] – Medication Dispenser and Prescription Placer Actors **SHALL** support querying the Community Pharmacy Manager for Dispensation and Prescription Documents using the “FindDispenses”, “FindPrescriptions”, and “FindPrescriptionsForDispense” stored queries. Other stored queries **MAY** be supported.

- [KDIS-057] – Upon successfully querying the Community Pharmacy Manager for Dispensation or Prescription Documents, a local audit trail **SHALL** be generated by the Medication Dispenser and Prescription Placer Actors. The content of the data **SHALL** be based upon the Audit trail events as specified in the IHE ATNA Integration and IHE CMPD Integration Profiles. See IS0101 *Saudi eHealth Security and Privacy Interoperability Specification* – Section 3.3.2 for more details.
- [KDIS-058] – When retrieving Dispensation or Prescription Documents (and related Pharmaceutical Advice Documents) from a HIE Document Repository, Medication Dispenser and Prescription Placer Actors **SHALL** be able to support the return of one or more documents.
- [KDIS-059] – Medication Dispenser and Prescription Placer Actor/Content Consumer **SHALL** be able to process the Dispensation Documents and all related Pharmaceutical Advice Documents as specified in IS0106 *Saudi eHealth Clinical Documents Constrains Interoperability Specifications* – Section 5.7 and Section 5.8.
- [KDIS-060] – Medication Dispenser and Prescription Placer Actor/Content Consumer **SHALL** be able to process the Prescription Documents and all related Pharmaceutical Advice Documents as specified in IS0106 *Saudi eHealth Clinical Documents Constrains Interoperability Specifications* – Section 5.6 and Section 5.8.
- [KDIS-061] – When retrieving Dispensation or Prescription Documents (and related Pharmaceutical Advice Documents) from a HIE Document Repository, Medication Dispenser and Prescription Placer Actors **SHALL** receive them in such a way that the receiving system is able to apply all updates or medication interaction checking issue management information contained in the related pharmaceutical advices before processing and/or displaying the information to the user.

4.1.4 Medication Interaction Reporting

The Medication Interaction Reporter Technical Actor is grouped with the Medication Dispenser and Pharmaceutical Adviser Technical Actors shown in Table 2.1-1 Interoperability conformance requirements for Dispenser. It uses the information returned by the [IHE XDS.b: Provide and Register Document Set-b ITI-41] transaction when present to inform the dispenser about the results of Medication Interaction Checking performed by the HIE Platform at the time of submission of the Dispensation or Update Record.

- [KDIS-065] – The Medication Interaction Reporter Technical Actor **SHALL** be grouped with the Medication Dispenser and Pharmaceutical Adviser Technical Actors and use the information returned in the [IHE XDS.b: Provide and Register Document Set-b ITI-41] transaction response to report to its users zero or more medication interaction issues detected. The information contained in each <RegistryError> element **SHALL** be presented to the user for each Medication Interaction Checking Issue found (See [KDIS-075] for the format of the issues reported).
- [KDIS-066] – The [IHE XDS.b: Provide and Register Document Set-b ITI-41] transaction may succeed or fail based on the outcome of the issues detected by medication interaction checking. The Medication Dispenser and Pharmaceutical Adviser **SHALL** implement all

cases specified in Table 4.2-3 Impact of medication interactions on the Provide and Register Transaction below.

[KDIS-067] – When a transaction [IHE XDS.b: Provide and Register Document Set-b ITI-41] has failed due to issues detected by Medication Interaction Checking, the Medication Interaction Reporter Actor grouped with the Medication Dispenser Actor **SHALL** implement a means for the Healthcare Provider to examine the issues and decide either in a change of the Dispensation or in the acceptance of the issues. If the Healthcare Provider decides to accept the issues, the Healthcare Provider **SHALL** have a means to document the reasons why the issues are accepted in Medication Interaction Checking Issue Management Records. The same or updated Dispensation Record **MAY** be re-submitted together with all Medication Interaction Checking Issue Management Records related to it.

4.2 REQUIREMENTS FOR HIE DOCUMENT REPOSITORY USE CASE ACTOR

4.2.1 Community Pharmacy Manager Technical Actor

The following rules shall be supported for the conformance to the Community Pharmacy Manager Actor:

[KDIS-070] When responding to a query, a Document Registry **SHALL** support the return of several medication documents for the same patient.

[KDIS-071] The Document Registry **SHALL** support the following stored queries:

FindDispenses

FindPrescriptions

FindPrescriptionsForDispense

4.2.2 Medication Interaction Checking

The following rules shall be supported for the conformance to the HIE Document Repository Actor:

The Medication Interaction Checking Technical Actor is grouped with the Document Repository Technical Actor. It performs Medication Interaction Checking and communicates the results by the [IHE XDS.b: Provide and Register Document Set-b ITI-41] transaction when issues have been detected to inform the prescriber.

[KDIS-075] – The Medication Interaction Checking Technical Actor **SHALL** be grouped with the Document Repository Technical Actor and return in the [IHE XDS.b: Provide and Register Document Set-b ITI-41] medication to return zero or more medication interaction issues detected in the <RegistryError> element within the <RegistryErrorList>. Each <RegistryError> element **SHALL** contain the information about exactly one medication interaction issue found:

- **errorCode**: A supplemental Error code value to those defined by IHE XDS, with the value: “MedicationInteractionCheckingIssue”

- severity: Based on the classification of the issue

TABLE 4.2-1 ERROR SEVERITY

MEDICATION INTERACTION ISSUE SEVERITY	RESPONSE
Warning or Error	urn:oasis:names:tc:ebxml-regrep:ErrorSeverityType:Error
Information	urn:oasis:names:tc:ebxml-regrep:ErrorSeverityType:Warning

- location: Source type (Prescription- or Dispense Item):

TABLE 4.2-2 SOURCE TYPE

SOURCE TYPE	Response
Prescription Item	PRE
Dispense Item	DIS

- codeContext: the textual representation of the error, which includes four concatenated elements separated by an underscore delimiter:
 - Medication Interaction Checking Issue Classification code (Error, Warning, and Information). Values **SHALL** be out of the “**KSA Medication Interaction Checking Issue Classification**” value set.
 - Medication Interaction Checking Issue Sub-error code conveying a high-level issue code. Values **SHALL** be out of the “**KSA Medication Interaction Checking Issue Code**” value set.
 - Medication Interaction Checking Issue Location Reference to Prescription or Dispense Item in the format: @root^@extension
 - Medication Interaction Checking Issue Text Message: Narrative Description of the Issue

Example of an ITI-41 transaction response with a <RegistryErrorList> including three <RegistryError> elements:

```
<RegistryResponse
  xmlns="urn:oasis:names:tc:ebxml-regrep:xsd:rs:3.0"
  status="urn:oasis:names:tc:ebxml-regrep:ResponseStatusType:Failure">
  <RegistryErrorList
    highestSeverity="urn:oasis:names:tc:ebxml-regrep:ErrorSeverityType:Error">
    <RegistryError
      errorCode="MedicationInteractionCheckingIssue"
      codeContext="E_DOSE_OID^1234_Narrative description of the error"
      location="PRE"
      severity="urn:oasis:names:tc:ebxml-regrep:ErrorSeverityType:Error"/>
    <RegistryError
      errorCode="MedicationInteractionCheckingIssue"
```

```

codeContext="W_DOSE_OID^7890_Narrative description of the warning"
location="PRE"
severity="urn:oasis:names:tc:ebxml-regrep:ErrorSeverityType:Error"/>
<RegistryError
  errorCode="MedicationInteractionCheckingIssue"
  codeContext="I_DOSE_OID^7890_Narrative description of the info"
  location="DIS"
  severity="urn:oasis:names:tc:ebxml-regrep:ErrorSeverityType:Warning"/>
:
</RegistryErrorList>
</RegistryResponse>

```

[KDIS-076] – The [IHE XDS.b: Provide and Register Document Set-b ITI-41] transaction may succeed or fail based on the outcome of the issues detected by medication interaction checking. The decision Table 4.2.1-3 below **SHALL** be implemented by the Document Repository when responding to this transaction.

TABLE 4.2-3 IMPACT OF MEDICATION INTERACTIONS ON THE PROVIDE AND REGISTER TRANSACTION

MEDICATION INTERACTION ISSUE SEVERITY	XDS REGISTRY ERROR ELEMENT VALUE	XDS TRANSACTION RESULT
Error	registry error Severity: Error	If one or more registry errors (transaction highest severity): Transaction Failure
Warning	registry error Severity: Error	If one or more registry errors (transaction highest severity): Transaction Failure
Information	registry error Severity: Warning	Registry warnings only (transaction highest severity): Transaction Success Prescription or Dispensation document(s) recorded
(No issue)	No registry error	Transaction Success Prescription or Dispensation document(s) recorded

[KDIS-077] – When a transaction [IHE XDS.b: Provide and Register Document Set-b ITI-41] has failed due to issues detected by Medication Interaction Checking, the Medication Interaction Checking Actor grouped with the Document Repository **SHALL** support the resubmission of the same or updated Dispensation Record with one or more Medication Interaction Checking Issue Management Records related to it. The Medication Interaction Checking Actor **SHALL** process the resubmitted Dispensation Record along with the Medication Interaction Checking Issue Management.

5. REFERENCED DOCUMENTS AND STANDARDS

TABLE 5-1 INTERNAL REFERENCES

MOH DOCUMENT	DESCRIPTION
IS0001 Saudi eHealth Core Interoperability Specification for KSA-Wide Patient Demographic Query	Documents the specifications required to obtain patient IDs and demographic information for the patient. It is used to ensure that the nationwide Health ID is used to register laboratory orders for the correct patient.
IS0007 Saudi eHealth Core Interoperability Specification for Clinical Notes and Summaries	Documents the specifications required to provide a synopsis of an encounter and detailed information about a specific type of encounter (e.g., Operative Note) with a patient.
IS0008 Saudi eHealth Core Interoperability Specification for ePrescriptions	Documents the specifications required to record a prescription in an outpatient environment including dosing information and additional clinical information to document the rationale behind the prescription as well as to support drug interaction checking.
IS0101 Saudi eHealth Security and Privacy Interoperability Specification	Specifies the interoperability standards and profiles along with the Saudi specific constraints that are required to provide the technical security measures, data protection, and privacy management that will facilitate the implementation of the Saudi eHealth Policies for Health Information Exchange in the Kingdom of Saudi Arabia among communicating IT systems.
IS0102 Saudi eHealth Document Sharing Interoperability Specification	Forms a “container” for set of requirements that complements the IHE XDS Profile with Saudi eHealth specific constraints when it is called upon by any of the Core Interoperability Specifications.
IS0106 Saudi eHealth Clinical Documents Constrains Interoperability Specifications	Specifies common constraints for clinical documents such as data elements of document headers that are common across the Saudi eHealth Project.
IS0200 Saudi eHealth Terminology Repository.	Specifies the terminology concepts and associated coded value sets for data elements used throughout the Saudi eHealth Interoperability Specifications.
UC0008 Saudi eHealth Medication Interoperability Use Case	<p>Provides for the recording of prescription and dispensation in an electronic form in order to improve patient care by Healthcare Provider access to the medication information of the patient.</p> <ul style="list-style-type: none"> • The Prescription Use Case conveys information necessary to ensure dispensers have the proper data to fulfill the dispensation including dosing information and additional clinical information to document the rationale behind the prescription as well as to support drug interaction checking. • The Dispensation Use Case enables Healthcare Providers to record a medication dispensation to a patient in an outpatient environment or at the time of an in-patient discharge. The Dispensation Record contains all information for the medication dispensed including active ingredient(s) as input for later drug interaction checking of new medication and lot/batch information needed for tracking purposes

MOH DOCUMENT	DESCRIPTION
UC0303 Saudi Health Information Exchange Policies	Contains the policies and supporting definitions that support the security and privacy aspects of the Saudi Health Information Exchange. The Saudi Health Information Exchange Policies apply to all individuals and organizations that have access to the Saudi Health Information Exchange managed health records, including those connected to the Saudi Health Information Exchange, their Business Associates, as well as any subcontractors of Business Associates. These policies apply to all information provided to or retrieved from the Saudi Health Information Exchange.

TABLE 5-2 EXTERNAL REFERENCES

STANDARD	DESCRIPTION
IHE IT Infrastructure (ITI) Technical Framework – Volume 1 (ITI TF-1) Integrations Profiles, Final Text Section 9: Audit Trail and Node Authentication (ATNA)	The Audit Trail and Node Authentication (ATNA) Integration Profile establishes security measures which, together with the Security Policy and Procedures, provide patient information confidentiality, data integrity and user accountability. May be obtained at http://www.ihe.net/Technical_Frameworks/#iti
IHE IT Infrastructure (ITI) Technical Framework – Volume 1 (ITI TF-1) Integrations Profiles, Final Text Section 7 – IHE Consistent Time (CT)	The Consistent Time Integration Profile (CT) provides a means to ensure that the system clocks and time stamps of the many computers in a network are well synchronized. This profile specifies synchronization with a median error less than 1 second. This is sufficient for most purposes. May be obtained at http://www.ihe.net/Technical_Frameworks/#iti
IHE IT Infrastructure (ITI) Technical Framework – Volume 1 (ITI TF-1) Integrations Profiles, Section 10 Cross-Enterprise Document Sharing (XDS.b)	The Cross-Enterprise Document Sharing (XDS.b) IHE Integration Profile facilitates the registration, distribution and access across health enterprises of patient electronic health records. This profile is focused on providing a standards-based specification for managing the sharing of documents between healthcare enterprises, ranging from a private physician office to a clinic to an acute care in-patient facility. May be obtained at http://www.ihe.net/Technical_Frameworks/#iti
IHE IT Infrastructure (ITI) Technical Framework – Volume 1 (ITI TF-1) Integrations Profiles, Section 13 Cross-Enterprise User Attestation (XUA) profile	Cross-Enterprise User Assertion Profile (XUA) - provides a means to communicate claims about the identity of an authenticated principal (user, application, system...) in transactions that cross enterprise boundaries. To provide accountability in these cross-enterprise transactions there is a need to identify the requesting principal in a way that enables the receiver to make access decisions and generate the proper audit entries. The XUA Profile supports enterprises that have chosen to have their own user directory with their own unique method of authenticating the users, as well as others that may have chosen to use a third party to perform the authentication. May be obtained at http://www.ihe.net/Technical_Frameworks/#iti
IHE Pharmacy - Community Medication Prescription and Dispense (CMPD) Integration Profile	The Community Medication Prescription and Dispense Integration Profile (CMPD) describes the process of prescription, validation and dispense of medication in the community domain. May be obtained at http://www.ihe.net/Technical_Frameworks/#pharmacy

STANDARD	DESCRIPTION
IHE Pharmacy Dispense (DIS) Content Profile	<p>The Pharmacy Dispense Document Profile (DIS) describes the content and format of a dispense document generated during the process in which a healthcare professional (in most cases, but not necessarily always, a pharmacist) hands out a medication to a patient.</p> <p>May be obtained at http://www.ihe.net/Technical_Frameworks/#pharmacy</p>
IHE Pharmacy Pharmaceutical Advice (PADV) Content Profile	<p>The Pharmacy Pharmaceutical Advice Document Profile (PADV) describes the content and format of a pharmaceutical advice generated during the process in which a healthcare professional (in most cases, but not necessarily always, a pharmacist) validates a Prescription Item of a prescription against pharmaceutical knowledge and regulations. The validation can be with regard to conflicts with other Prescription Items or current medication of the patient or other reasons which affect the further processing of the Prescription Item (may be dispensed with change, etc.).</p> <p>May be obtained at http://www.ihe.net/Technical_Frameworks/#pharmacy</p>
IHE Pharmacy Prescription (PRE) Content Profile	<p>The Pharmacy Prescription Document Profile (PRE) describes the content and format of a prescription document generated during the process in which a healthcare professional (in most cases, but not necessarily always, a medical specialist or a general practitioner) decides that the patient needs medication. A prescription is an entity that can be seen as an order to anyone entitled to dispense (prepare and hand out) medication to the patient.</p> <p>May be obtained at http://www.ihe.net/Technical_Frameworks/#pharmacy</p>
Logical Observation Identifiers Names and Codes (LOINC®)	<p>A database of universal identifiers for laboratory and other clinical observations. The laboratory portion of the LOINC database contains the usual categories of chemistry, hematology, serology, microbiology (including parasitology and virology), and toxicology; as well as categories for drugs and the cell counts typically reported on a complete blood count or a cerebrospinal fluid cell count. Antibiotic susceptibilities are a separate category. The clinical portion of the LOINC database includes entries for vital signs, hemodynamics, intake/output, EKG, obstetric ultrasound, cardiac echo, urologic imaging, gastro endoscopic procedures, pulmonary ventilator management, selected survey instruments, and other clinical observations. For more information visit www.loinc.org.</p>

5.1 COPYRIGHT PERMISSIONS

IHE:

IHE materials used in this document have been extracted from relevant copyrighted materials with permission of Integrating the Healthcare Enterprise (IHE) International. Copies of this standard may be retrieved from the IHE Web Site at www.ihe.net<<http://www.ihe.net/>>.

LOINC:

"This product includes all or a portion of the LOINC® table, LOINC panels and forms file, LOINC document ontology file, and/or LOINC hierarchies file, or is derived from one or more of the foregoing, subject to a license from Regenstrief Institute, Inc. Your use of the LOINC table, LOINC codes, LOINC panels and forms file, LOINC document ontology file, and LOINC

hierarchies file also is subject to this license, a copy of which is available at <http://loinc.org/terms-of-use>. The current complete LOINC table, LOINC Users' Guide, LOINC panels and forms file, LOINC document ontology file, and LOINC hierarchies file are available for download at <http://loinc.org>. The LOINC table and LOINC codes are copyright © 1995-2013, Regenstrief Institute, Inc. and the Logical Observation Identifiers Names and Codes (LOINC) Committee. The LOINC panels and forms file, LOINC document ontology file, and LOINC hierarchies file are copyright © 1995-2014, Regenstrief Institute, Inc. All rights reserved. THE LOINC TABLE (IN ALL FORMATS), LOINC PANELS AND FORMS FILE, LOINC DOCUMENT ONTOLOGY FILE, AND LOINC HIERARCHIES ARE PROVIDED "AS IS." ANY EXPRESS OR IMPLIED WARRANTIES ARE DISCLAIMED, INCLUDING, BUT NOT LIMITED TO, THE IMPLIED WARRANTIES OF MERCHANTABILITY AND FITNESS FOR A PARTICULAR PURPOSE. LOINC® is a registered United States trademark of Regenstrief Institute, Inc. A small portion of the LOINC table may include content (e.g., survey instruments) that is subject to copyrights owned by third parties. Such content has been mapped to LOINC terms under applicable copyright and terms of use. Notice of such third party copyright and license terms would need to be included if such content is included."

6. APPENDIX A – SAMPLE MESSAGES

EXAMPLES WILL BE PROVIDED AS PART OF THE IS SPECIFICATION VALIDATION PROCESS. UNTIL THEN THIS SECTION WILL REMAIN BLANK.